

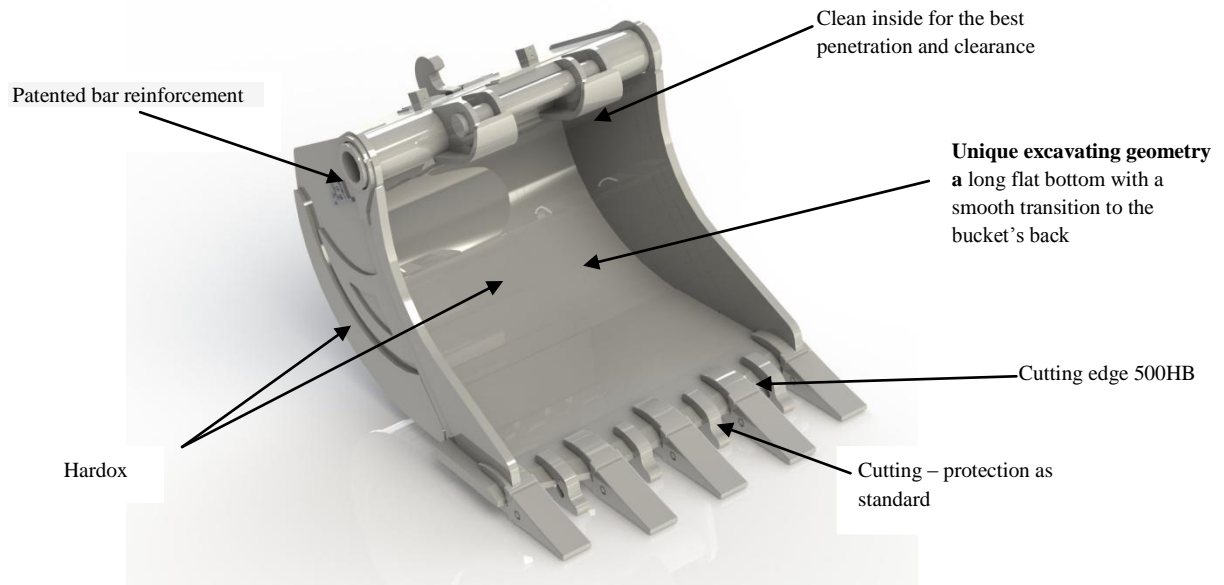

# EXC. BUCKET 2000L-5100L

## BUCKETS 2000L-5100L

ABL's buckets are in this range designed for the very hardest conditions. They are popular and designed with cutting edges for an effective penetration into the material. The clean inside facilitates penetration/ clearance of the bucket and prevents accumulation of material at the same time.



**ABL CE**, in this range offer as standard buckets from **2000L** till **5100L**.

Widths from **1500mm** till **2300mm**. Delivered with quick couplers or fixed attachment. Attachment S80-S100, SMP105, S3 or a fixed attachment. Teeth from 5.5" to 6.0".

### Option teeth / cutting equipment

- Straight cut or blunt cut
- Teeth from 5.5" - 6.0"
- For a larger volume or extra equipment, please ask for a quotation

### Advantages

- + Durable
- + Easy digging with good penetration
- + Clean inside

**Please contact the nearest retailer or ABL Construction Equipment for more information or a quotation.**

ABL Construction Equipment | Svetsargatan 1 | 576 33 Sävsjö | Tel +46 382 67600 | [info@abl.se](mailto:info@abl.se) | [www.abl.se](http://www.abl.se)

