

HYDRALIC GRADING BUCKET

This is a bucket which is developed and designed for all areas of use from fine-grading to demanding rock removal. The bucket is rotatable 2x45° with two protected vertical cylinders. There is a big gap and tapered gables to make it easier to operate different kinds of performance. The drop prevents and reinforces the sides of the bucket.

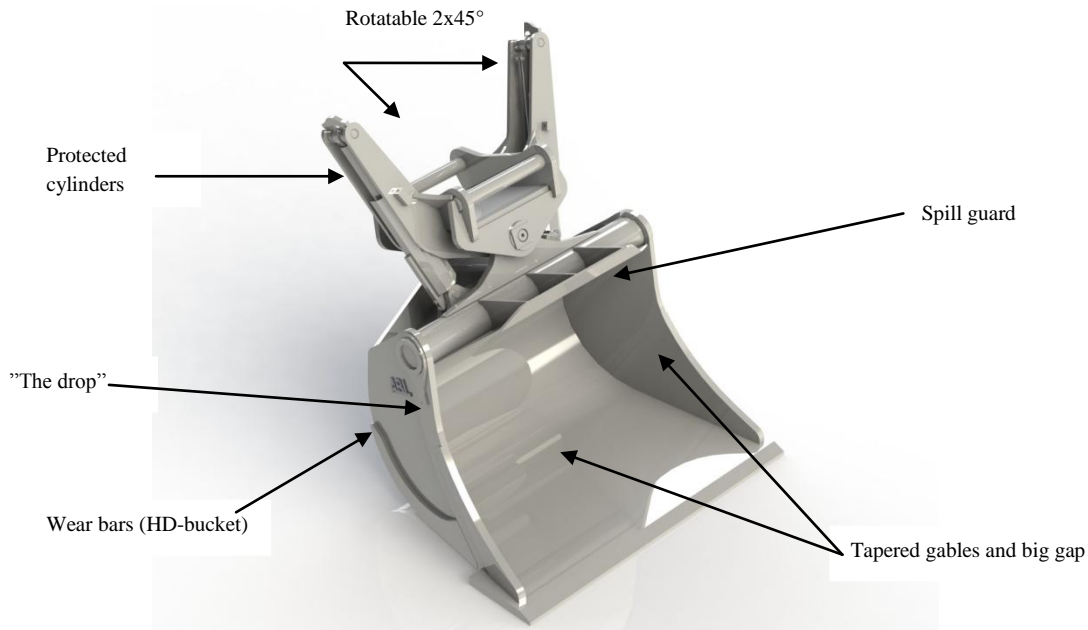

ABL CE, can in this range as standard offer grading buckets from **650L** to **3000L**. Widths between **1500mm** to **2600mm**. HD and LT execution. HD bucket with abrasion resistant steel and LT without abrasion resistant steel. S60-S100 attachments as standard. S1-S3 depended on size.

Advantages

- + Maximum strength
- + Good durability
- + Clean inside
- + Rotatable 2x45°
- + Spill guard

Please contact your closest retailer or ABL Construction Equipment for more information or a quotation.

ABL Construction Equipment | Svetsargatan 1 | 576 33 Sävsjö | Tel +46 382 67600 | info@abl.se | www.abl.se

