

MECHANICAL (HYDRAULIC) PALLET FORK FOR EXCAVATORS

The pallet fork can also be used by excavators. The same design as used by wheel-loaders with attachment fitted for excavators. With good sight, chromed axle, plain bearings (Oilon) and attachment for quick couplers as standard, it is a pallet fork with high quality.

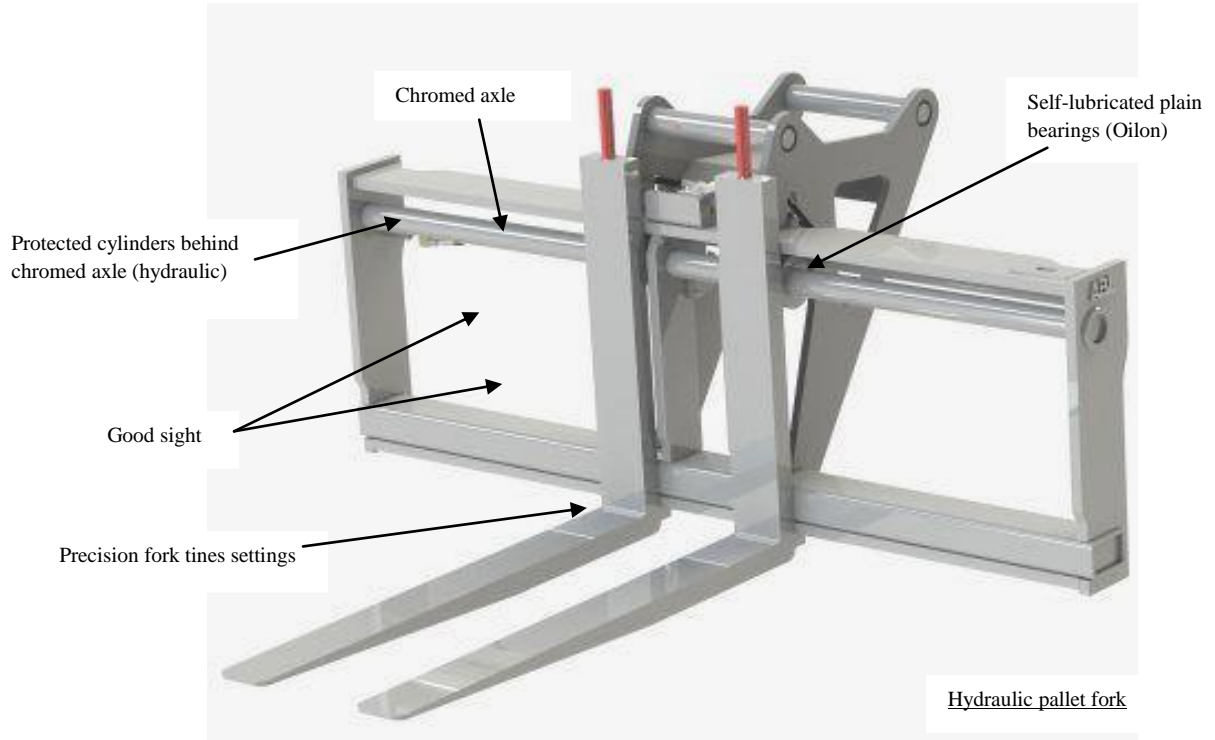

ABL CE can in this range as standard offer mechanical pallet fork from **1.0tons** to **5.0tons** and a frame width **1000mm** to **1500mm**. The length of the fork tines are **1200mm** as standard. Depending on sizes there are attachments for quick couplers S40-S70 or S1-S3. The pallet fork's capacity is by tp. 600mm.

Options

- Hydraulic pallet fork
- If you need a customized pallet fork, please write a quotation.

Advantages

- + No noise
- + Protected cylinders (hydraulic)
- + Precision of fork tines-settings
- + Self-lubricated plain bearings on chromed axle
- + Good sight

Please contact your nearest retailer or ABL Construction Equipment for more information or a quotation.

ABL Construction Equipment | Svetsargatan1 | 576 33 Sävsjö | Tel +46 382 67600 | info@abl.se | www.abl.se



Bästa lösningen finns ofta
rakt framför näsan.